

**Series: COMPACT-FAN Type D/DS**

double inlet  
with forward curved blades

**FISCHBACH**

Luft- und Ventilatorentechnik GmbH

**Type: DS6-770/E65**

**ERP KONFORM**

**CE** -conform



**manufacturer:**

Fischbach Luft- und Ventilatorentechnik GmbH  
Am Hellerberg 22-24  
D-57290 Neunkirchen

phone: ++49(0)2735/777-0

telefax: ++49(0)2735/770-625

internet: www.fischbach-luft.de

email: info@fischbach-luft.de

**Technical Data**

weight:	(kg)	27
material housing:	steel, galvanized	
material impeller:	steel, galvanized	
direction of rotation:	left	
protection class:	IP 65	
insulation class:	F	
motor protection:	thermal contact	

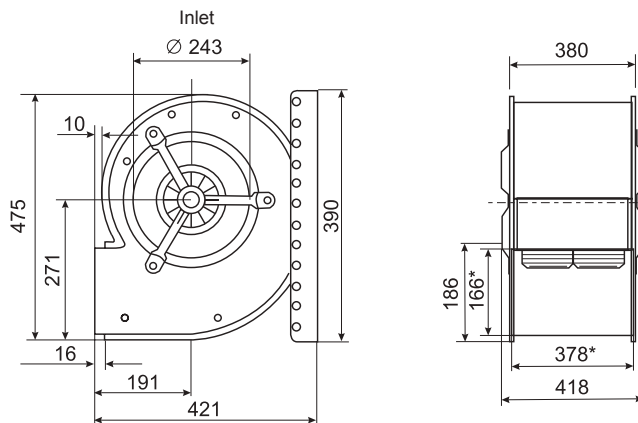

\*external dimension of discharge

**connection plan**

0.11-1 I.

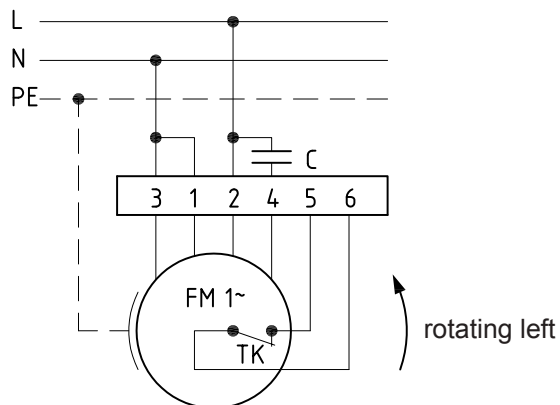

the silent one



Series: **COMPACT-FAN Type D/DS**

double inlet  
with forward curved blades

**FISCHBACH**

Luft- und Ventilatorentechnik GmbH

Type: **DS6-770/E65**

ErP 2013 2015 x 2018

**Performance data**

main voltage:	(V)	230 (1~)
frequency:	(Hz)	50
current max.:	(A)	5,9
power input max.:	(kW)	1,3
air flow volume max.:	(m <sup>3</sup> /h)	4602
statical pressure max.:	(Pa)	572
speed max.:	(rpm)	1441
supply air temperature:	(°C)	-25... +60
capacitor:	(µF)	30

**ErP-Data:**

total efficiency fan ( $\eta_e$ ):	(%)	41,1
installation category:		A
efficiency category:		static
efficiency grade: N	(%)	44
target efficiency ( $\eta_{target}$ ):	(%)	37,3
speed controller		no
year of manufacturing		since 2015
manufacturer:	Fischbach Luft- und Ventilatorentechnik GmbH D-57290 Neunkirchen / HRB 5804 Siegen	
order no.		18011922
power input:	(kW)	0,88
air flow volume:	(m <sup>3</sup> /h)	2757
statical pressure:	(Pa)	472
speed:	(rpm)	1325
specific ratio:		1

disassembling/recycling/disposal: see page decommission

installation/operation/maintenance: see operating and mounting instructions

measurement for determination of efficiency without additional items

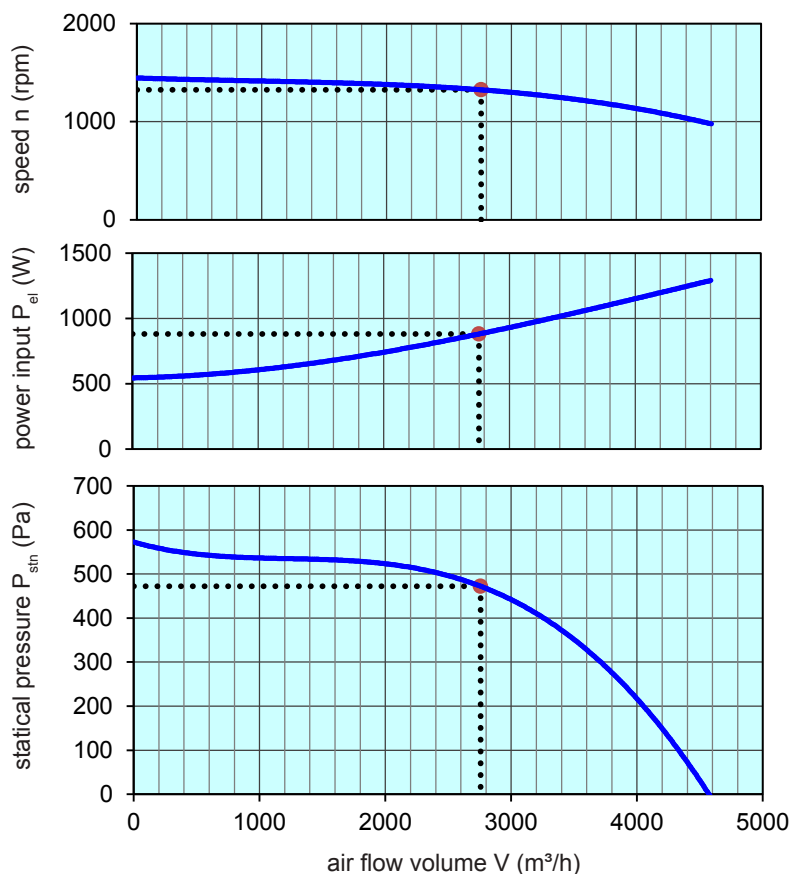

Speed controller / accessories / sound data, please see in the appropriate table

Technical documentation according to page: **General information**